

Top View

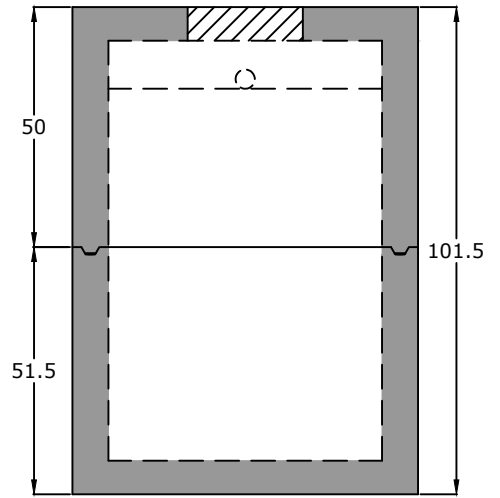

End View

Notes:

- ASTM C 1613 Compliant
- HS20 Traffic Rated
- 4" Inlet/Outlet (Standard)
- 4" PVC 90 in Baffle Wall
- 2/3 - 1/3 Compartment Capacity

ASTM C 990 Butyl Sealant

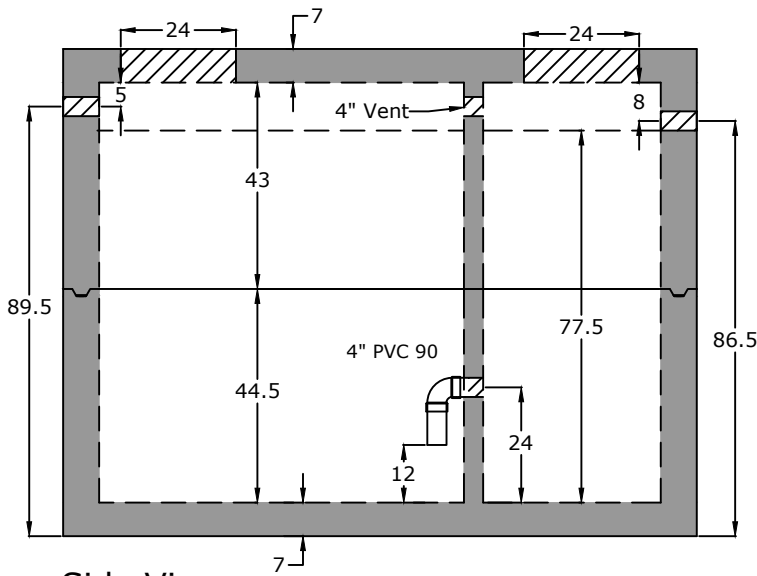
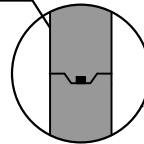

Side View

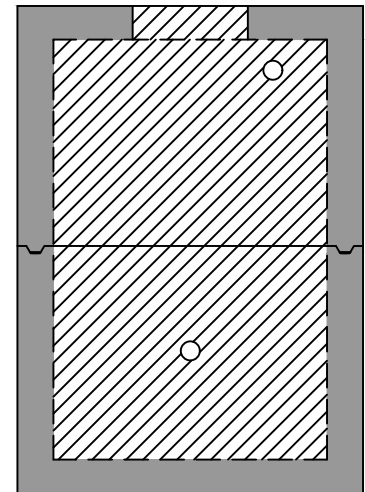

Baffle View

Specifications

- Concrete:** 5,000 psi minimum strength (28 day)
- Reinforcing:** Primary reinforcement will be rebar.
- Risers:** Grade rings and manhole frames and covers sold separately.
- Sealant:** Sealant used in the seam of the tank will meet or exceed ASTM C990.
- Pipe Penetrations:** Inlet and outlets are fitted with seals that meet or exceed all ASTM C923 specifications.
- Partition Wall:** The partition wall, if present, is poured monolithically.
- Drawing:** All measurements are accurate within ± 1 inch.

Tank Warranty: See Terms & Conditions.

Centroid(s): Lid (67, 36), Base (67, 36)

BARGER
PRECAST

Weights
Top - 16,436 lb
Bottom - 17,372 lb

Anti-Float Protection
5" of water

Installation: The tank hole is not to be more than 18 in. longer and wider than the tank. There shall be a minimum of 6" of 3/4" stone bedding. This tank is designed for HS20 traffic loads and with a max backfill cover of 8" and a minimum of 6".

2,500 Gallon HS20 Oil Water Separator

P.O. Box 370 - Kingston TN 37763
Phone 888.882.5860 - BargerPrecast.com

Date: 2.162017

Drawn By: Eric Barger

Updated: 8.232024