

Eccentric Cone

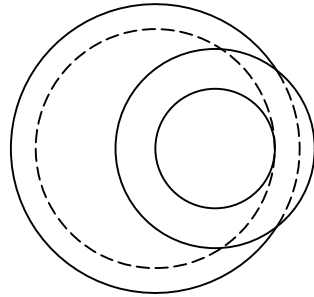

Eccentric Cone

- 20" - 1,900 lb
- 24" - 2,200 lb
- 28" - 2,500 lb
- 36" - 3,100 lb
- 44" - 3,800 lb

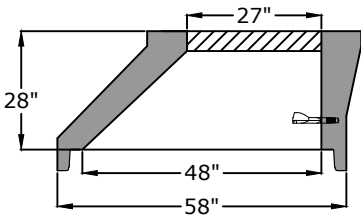
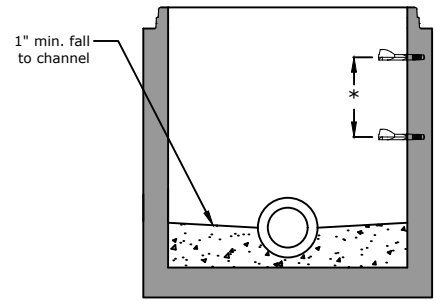

Manhole Base Preformed Invert Detail

Riser

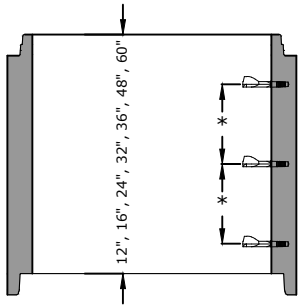

Riser Weights

- 12" - 900 lb
- 16" - 1,150 lb
- 24" - 1,750 lb
- 32" - 2,300 lb
- 36" - 2,600 lb
- 48" - 3,450 lb
- 60" - 4,300 lb

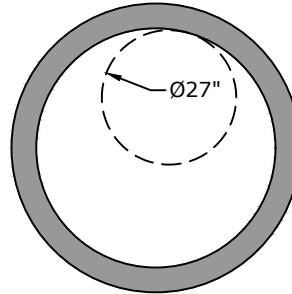

Flat Top

- 27" dia. standard size for sewer
- Storm opening will match casting opening



Flat Top

- 8" - 1,850 lb.** Most common
- 10" - 2,250 lb
- 12" - 2,750 lb

Monolithic Base

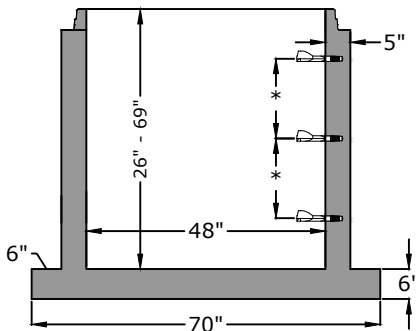

Base Weights

- 24" - 3,730 lb
- 32" - 4,320 lb
- 36" - 4,600 lb
- 38" - 4,730 lb
- 48" - 5,500 lb
- 52" - 5,762 lb
- 60" - 6,350 lb
- 69" - 7,000 lb

Flat Top - Rectangular Openings

- 24" x 24"
- 28" x 28"
- 24" x 34"
- 19" x 30"

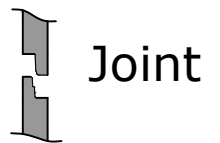

Approved for Production

Project: _____

Date: _____

Quantity: _____

By: _____

Drawn by: Eric Barger

Date: 08.012024

Concrete: 4,500 psi minimum 28 day compressive strength
Reinforcing: Per ASTM C478 with design calculations performed by a Licensed P.E. Minimum 2" cover of all reinforcing steel.
Pipe Penetrations: All pipe penetrations are placed according to job requirements.
Pipe Seals: All pipe boots will meet ASTM C 923.
Sealant: Sealant used will meet ASTM C 990.
Steps: On 16" centers unless otherwise specified.
Preformed Invert: As required by plans or governing specifications.

**BARGER
PRECAST**

P.O. Box 370 - Kingston TN 37763
 Phone 888.882.5860 - BargerPrecast.com

**48" Ø Manhole w/ Monolithic Extended
Base Slab
ASTM C-478 Compliant**