

Notes

Flat Top Weight - 1,600 lb

Top View

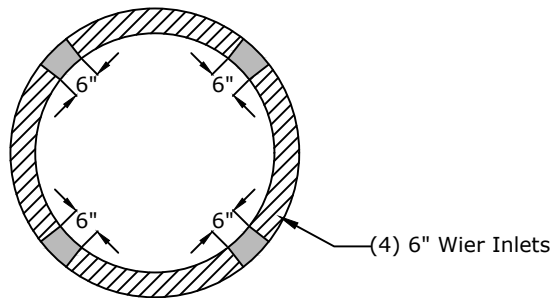

Flat Top

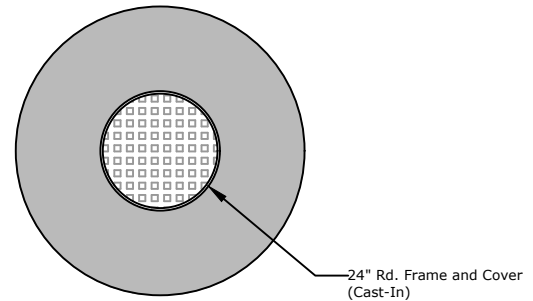
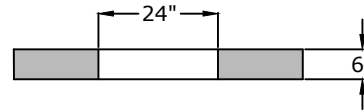

Side View

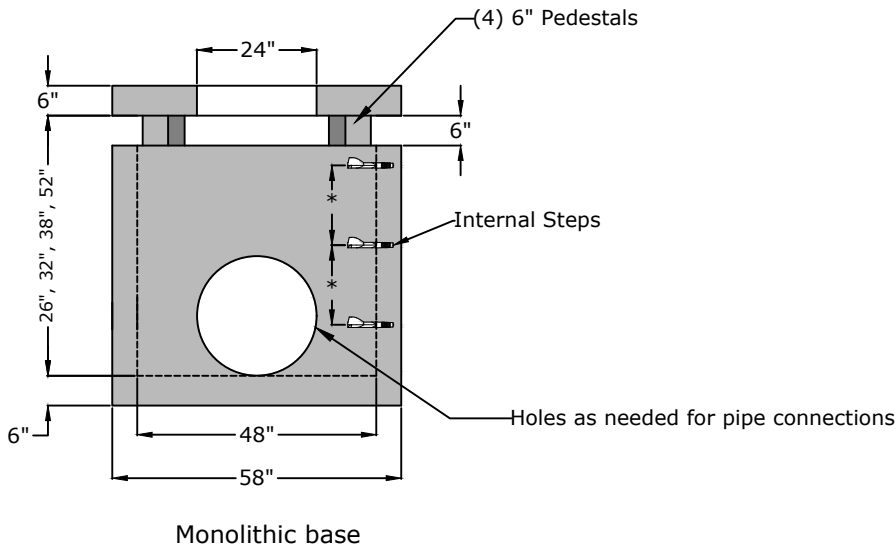

Approved for Production

Project: _____

Date: _____

Quantity: _____

By: _____

Drawn by: Eric Barger

Date: 07.312024

Concrete: 4,500 psi minimum 28 day compressive strength

Reinforcing: Per ASTM C478 with design calculations performed by a Licensed P.E. Minimum 2" cover of all reinforcing steel.

Pipe Penetrations: All pipe penetrations are placed according to job requirements.

Pipe Sealant: Pipes to be sealed into structure with grout.

Sealant: Sealant used will meet ASTM C923.

Steps: On 16" centers unless otherwise specified.

BARGER PRECAST

P.O. Box 370 - Kingston TN 37763
Phone 888.882.5860 - BargerPrecast.com

**48" I.D Drop Inlet
ASTM C-478 Compliant**