

Top View

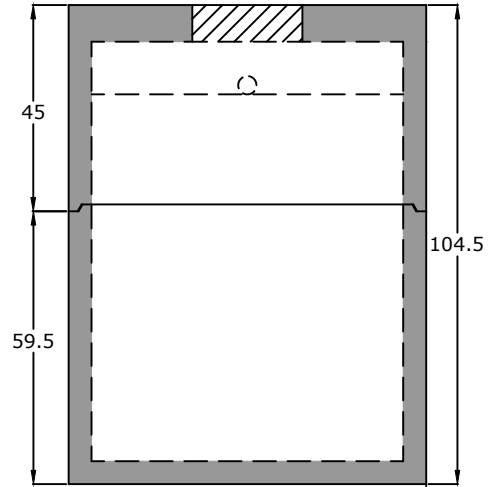

End View

- Notes:**
 ASTM C 1613 Compliant
 HS20 Traffic Rated
 4" Inlet/Outlet (Standard)
 4" PVC 90 in Baffle Wall
 2/3 - 1/3 Compartment Capacity

ASTM C 990 Butyl Sealant

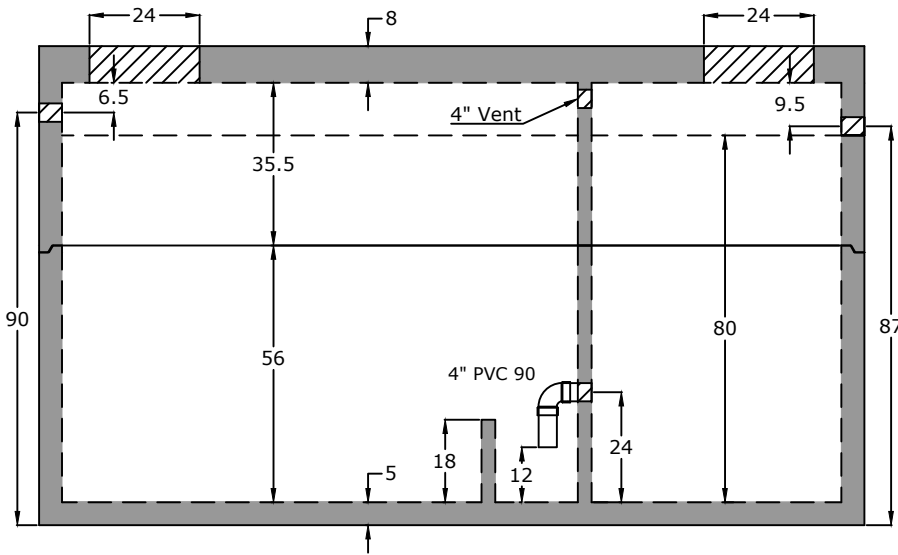
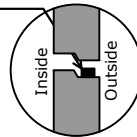

Side View

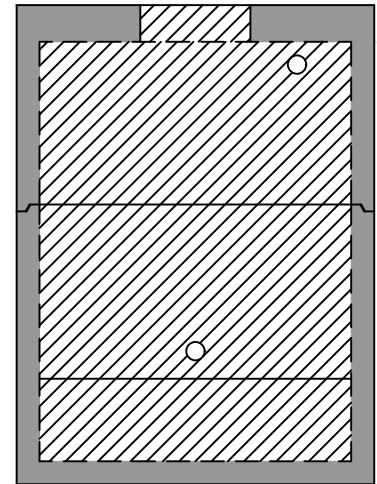

Baffle View

Specifications

- Concrete:** 5,000 psi minimum strength (28 day)
Reinforcing: Primary reinforcement will be rebar.
Risers: Grade rings and manhole frames and covers sold separately.
Sealant: Sealant used in the seam of the tank will meet or exceed ASTM C990.
Pipe Penetrations: Inlet and outlets are fitted with seals that meet or exceed all ASTM C923 specifications.
Partition Wall: The partition wall, if present, is poured monolithically.
Drawing: All measurements are accurate within ± 1 inch.

Tank Warranty: See Terms and Conditions.

Centroid(s): Lid (91, 39), Base (92, 39)

BARGER
PRECAST

Weights
 Top - 17,161 lb
 Bottom - 18,886 lb

Anti-Float Protection
 42" of water

Installation: The tank hole is not to be more than 18 in. longer and wider than the tank. There shall be a minimum of 6" of 3/4" stone bedding. This tank is designed for HS20 traffic loads and with a max backfill cover of 3' and a minimum of 6".

P.O. Box 370 - Kingston TN 37763
 Phone 888.882.5860 - BargerPrecast.com

4,000 Gallon HS20 Grit Tank
First Utility District - Knoxville, TN

Date: 5.132019

Drawn By: Eric Barger

Updated: 8.202024