

Top View

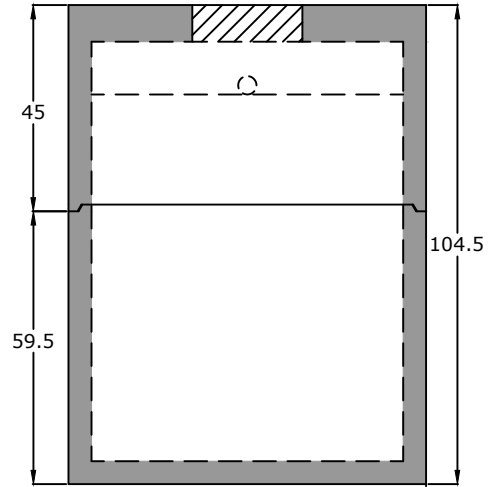

End View

**Notes:**  
 ASTM C 1613 Compliant  
 HS20 Traffic Rated  
 4" Inlet/Outlet (Standard)  
 6" Hole in Baffle Wall  
 2/3 - 1/3 Compartment Capacity

ASTM C 990 Butyl Sealant

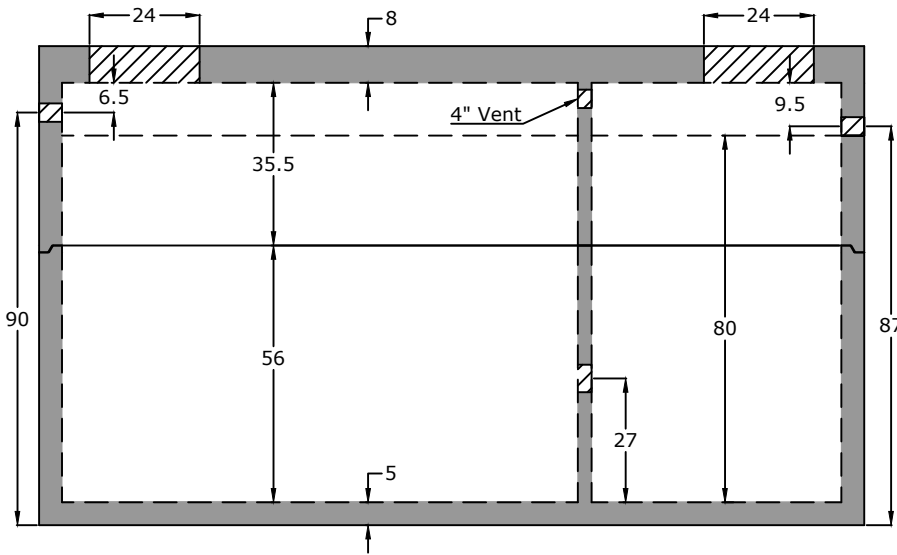
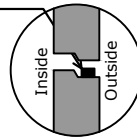

Side View

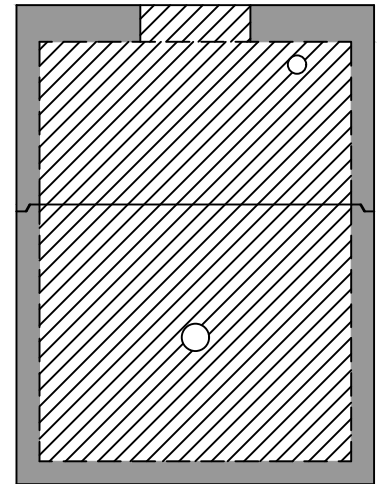

Baffle View

**Specifications**

**Concrete:** 5,000 psi minimum strength (28 day)  
**Reinforcing:** Primary reinforcement will be rebar.  
**Risers:** Grade rings and manhole frames and covers sold separately.  
**Sealant:** Sealant used in the seam of the tank will meet or exceed ASTM C990.  
**Pipe Penetrations:** Inlet and outlets are fitted with seals that meet or exceed all ASTM C923 specifications.  
**Partition Wall:** The partition wall, if present, is poured monolithically.  
**Drawing:** All measurements are accurate within  $\pm 1$  inch.

**Tank Warranty:** See Terms and Conditions.

**Centroid(s):** Lid (91, 39), Base (92, 39)

**BARGER  
 PRECAST**

**Weights**  
 Top - 17,161 lb  
 Bottom - 18,886 lb

**Anti-Float Protection**  
 42" of water

**Installation:** The tank hole is not to be more than 18 in. longer and wider than the tank. There shall be a minimum of 6" of 3/4" stone bedding. This tank is designed for HS20 traffic loads and with a max backfill cover of 3' and a minimum of 6".

**4,000 Gallon HS20 Grease Trap  
 MWSD - Murfreesboro, TN**

P.O. Box 370 - Kingston TN 37763  
 Phone 888.882.5860 - BargerPrecast.com

Date: 5.102010

Drawn By: Eric Barger

Updated: 7.242024