

**Top View**

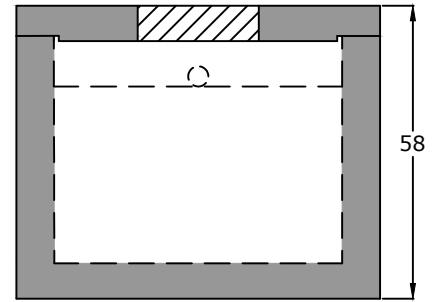

**End View**

**Notes:**

- ASTM C 1613 compliant
- HS20 Traffic Rated
- 4" Inlet/Outlet (Standard)
- 4" PVC 90 in Baffle Wall
- 2/3 - 1/3 Compartment Capacity

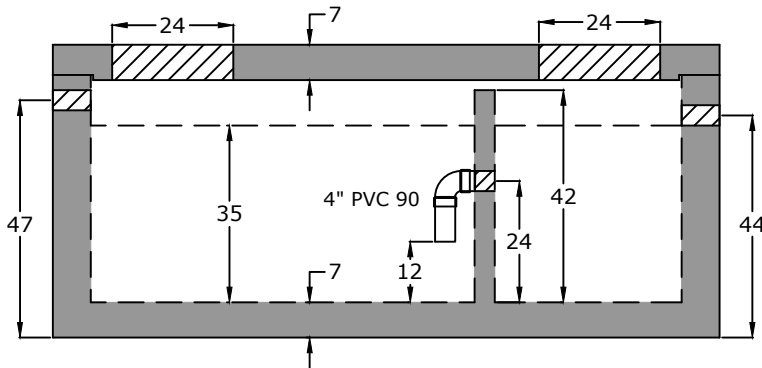
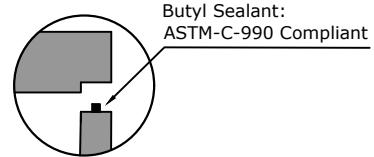

**Side View**

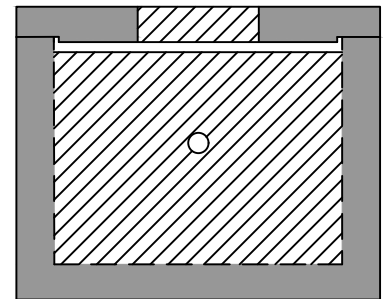

**Baffle View**

**Specifications**

- Concrete:** 5,000 psi minimum strength (28 day)
- Reinforcing:** Primary reinforcement will be rebar.
- Risers:** Grade rings and manhole frames and covers sold separately.
- Sealant:** Sealant used in the seam of the tank will meet or exceed ASTM C990.
- Pipe Penetrations:** Inlet and outlets are fitted with seals that meet or exceed all ASTM C923 specifications.
- Partition Wall:** The partition wall, if present, is poured monolithically.
- Drawing:** All measurements are accurate within  $\pm 1$  inch.

**Tank Warranty:** See Terms and Conditions.

**Centroid(s):** Lid (66, 36), Base (67, 36)

**BARGER**  
**PRECAST**

**Weights**  
Top - 4,913 lb  
Bottom - 17,202 lb

**Anti-Float Protection**  
0" of water

**Installation:** The tank hole is not to be more than 18 in. longer and wider than the tank. There shall be a minimum of 6" of 3/4" stone bedding. This tank is designed for HS20 traffic loads and with a max backfill cover of 8" and a minimum of 6".

**1,000 Gallon HS20 Grease Trap**

P.O. Box 370 - Kingston TN 37763  
Phone 888.882.5860 - BargerPrecast.com

Date: 2.132024

Drawn By: Eric Barger

Updated: 7.222024

Lift loop

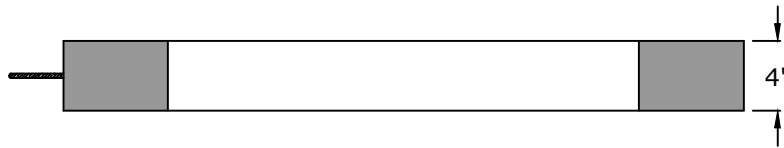

~206 lb

Lift loop

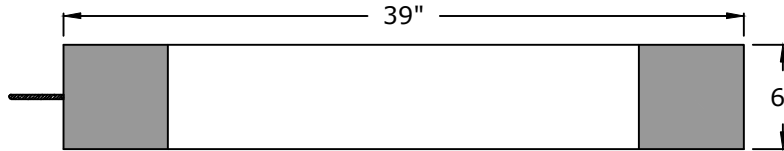

~309 lb

Lift loop

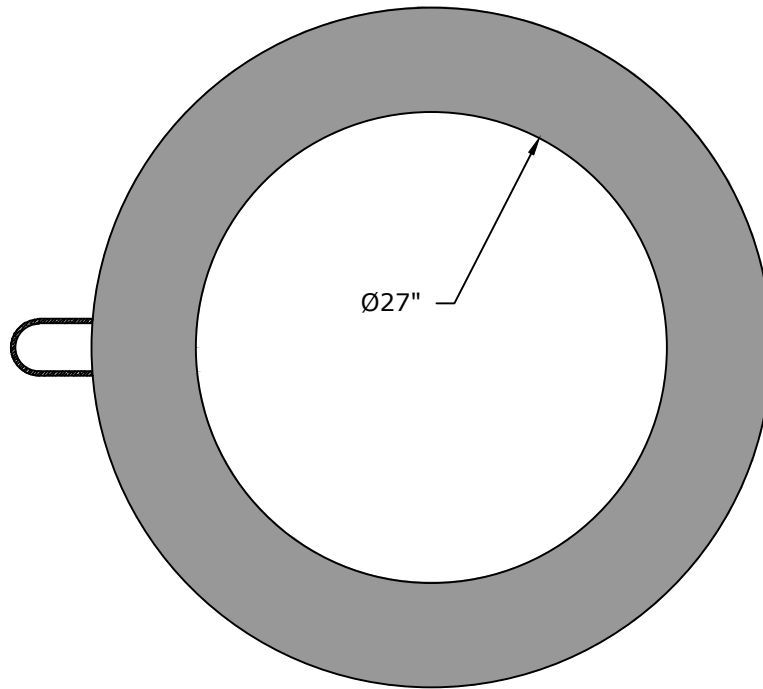

**Approved for Production**

Project: \_\_\_\_\_

Date: \_\_\_\_\_

Quantity: \_\_\_\_\_

By: \_\_\_\_\_

**BARGER**  
**PRECAST**

**Specifications**

Concrete: 4,000 PSI

**Concrete Grade Ring**  
**27" I.D.**

C.R. Barger & Sons, Inc.  
P.O. Box 370 - Kingston TN 37763  
Phone 888.882.5860 - BargerAndSons.com

Date: 2.252020

Drawn By: Eric Barger

**Shipping:** 123 Pawnook Farm Road • Lenoir City TN 37771  
**Mailing:** P.O. Box 370 • Kingston TN 37763

**Phone:** (865) 270-8080  
**Fax:** (865) 882-6394  
**Website:** www.BargerAndSons.com

*Five generations. One goal. Quality precast concrete.*

**Manhole Frame and Cover**

Height  
7"

Clear Opening  
24"

Estimated Weight  
Frame: 310 lbs

Load Rating  
Heavy Duty  
H-20 Traffic Rated

Lid Type  
Solid (Non-vented)

