

Top View

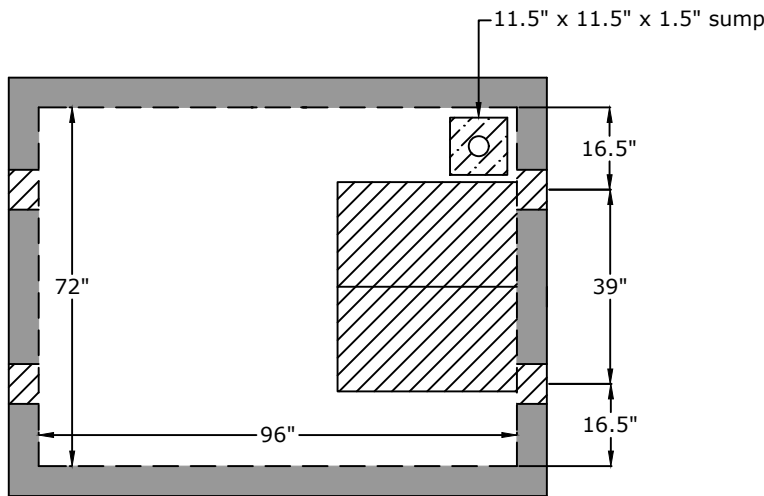

Notes

Lid weight - 11,500 lb  
 Body weight - 4,900 lb

**\*\*TRAFFIC RATED\*\***

Side View

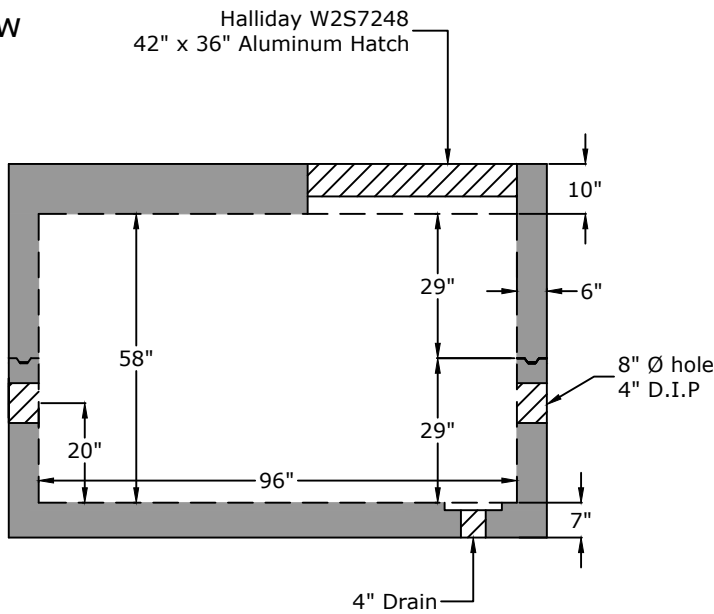

Joint Detail

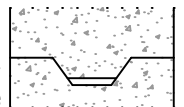

Positive Lock Male/Female Keyway  
 +/- 0.005" tolerance

**Approved for Production**

Project: \_\_\_\_\_

Date: \_\_\_\_\_

Quantity: \_\_\_\_\_

By: \_\_\_\_\_

Drawn by: Samantha Lowe

Date: 10.172024

**Concrete:** 5,000 psi minimum strength (28 day)  
**Reinforcing:** Primary reinforcement will be rebar (Grade 60) rebar.  
**Pipe Penetrations:** All pipe penetrations are placed according to job requirements.  
**Sealant:** Sealant used will meet or exceed ASTM C990.  
**Steps:** If required, will be aligned under the hatch unless specified.  
**General:** Meter vaults are not water tight structures unless specified by Barger Precast.  
**Tank Warranty:** See Terms and Conditions.

**BARGER  
 PRECAST**

P.O. Box 370 - Kingston TN 37763  
 Phone 888.882.5860 - BargerPrecast.com

**8' x 6' x 58" - HS20 4" Domestic Meter Vault  
 City of Brentwood Water Services Detail**