

Top View

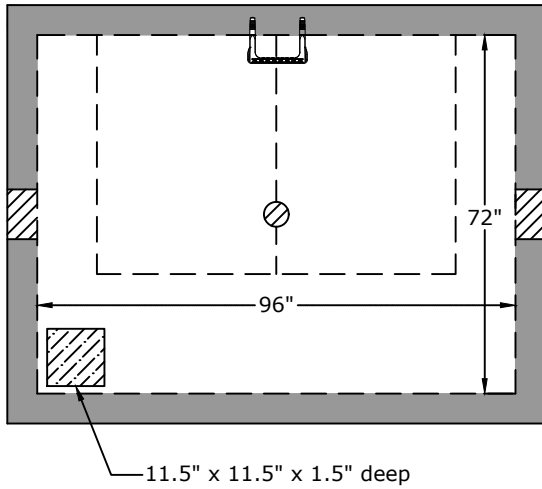

Notes

Lid weight - 8,800 lb
 Body weight - 6,700 lb

Side View

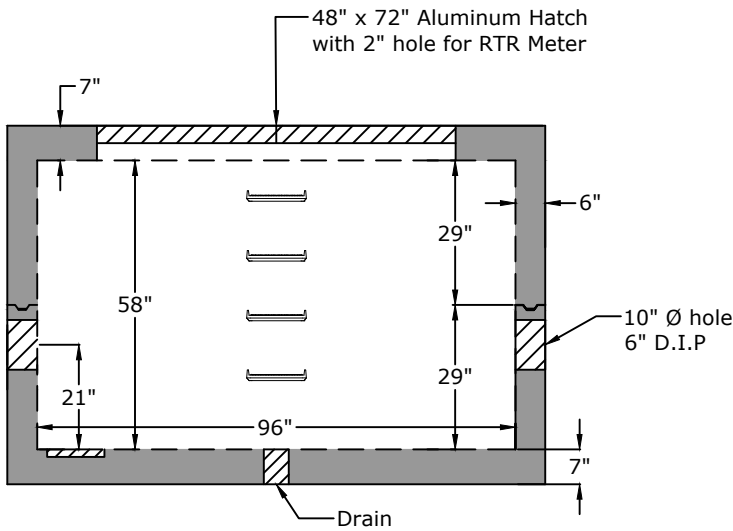

Joint Detail

Positive Lock Male/Female Keyway
 +/- 0.005" tolerance

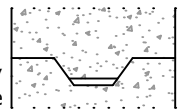

Approved for Production

Project: _____

Date: _____

Quantity: _____

By: _____

Drawn by: Samantha Lowe

Date: 10.172024

Concrete: 5,000 psi minimum strength (28 day)
Reinforcing: Primary reinforcement will be rebar (Grade 60) rebar.
Pipe Penetrations: All pipe penetrations are placed according to job requirements.
Sealant: Sealant used will meet or exceed ASTM C990.
Steps: If required, will be aligned under the hatch unless specified.
General: Meter vaults are not water tight structures unless specified by Barger Precast.
Tank Warranty: See Terms and Conditions.

BARGER PRECAST

P.O. Box 370 - Kingston TN 37763
 Phone 888.882.5860 - BargerPrecast.com

**8' x 6' x 58" - 6" Fire Meter Vault
 Hendersonville Utility District**