

Top View

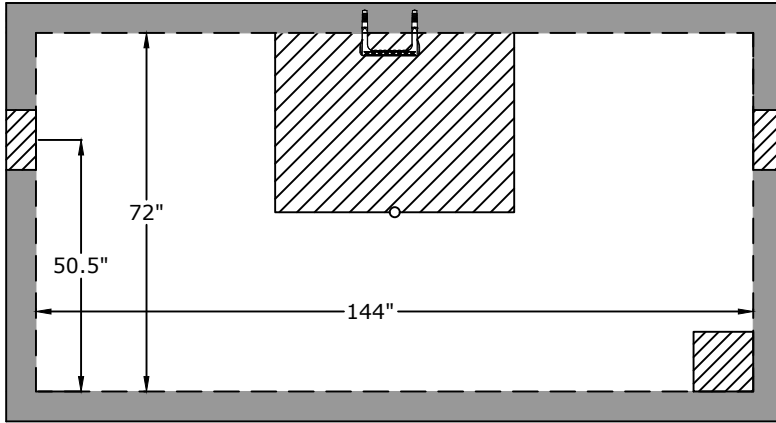

Notes

Top Weight - 7,000 lb  
Bottom Weight- 23,700 lb

Side View

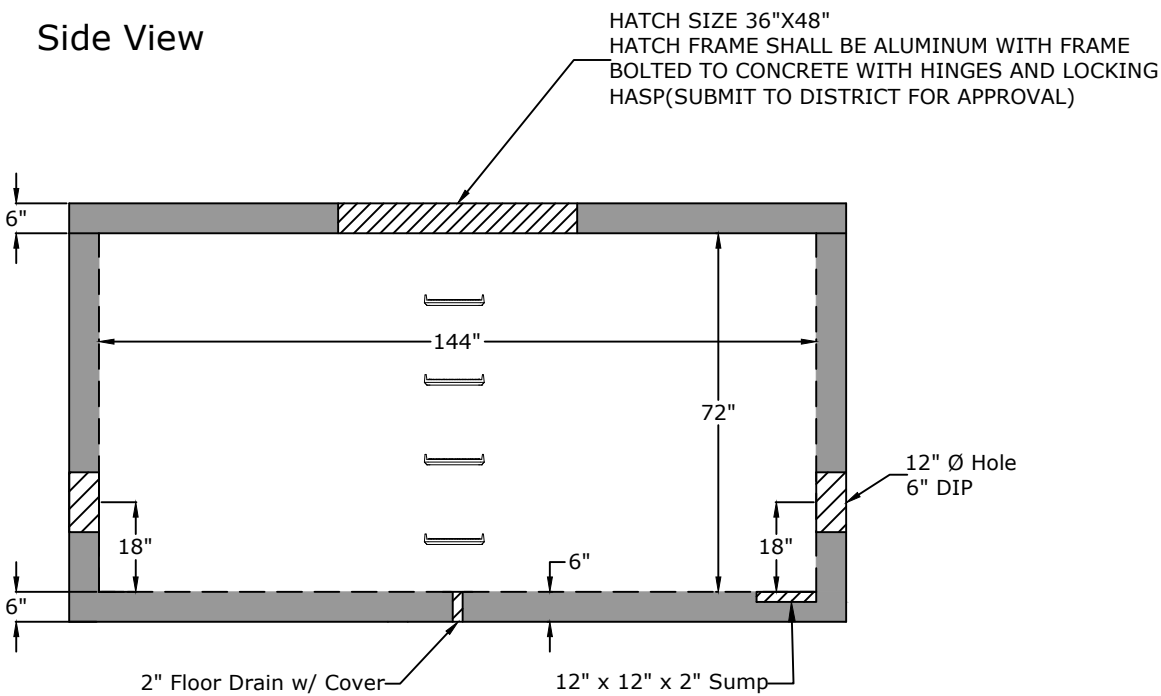

Approved for Production

Project: \_\_\_\_\_

Date: \_\_\_\_\_

Quantity: \_\_\_\_\_

By: \_\_\_\_\_

**BARGER**  
**PRECAST**

Specifications

- Concrete:** 5,000 psi minimum strength (28 day)
- Reinforcing:** Primary reinforcement will be a #3 rebar (Grade 60) rebar.
- Pipe Penetrations:** All pipe penetrations are placed according to job requirements.
- Sealant:** Sealant used will meet or exceed ASTM C990.
- Steps:** If required, the steps will be aligned under hatch unless specified.

C.R. Barger & Sons, Inc.  
P.O. Box 370 - Kingston TN 37763  
Phone 888.882.5860 - BargerAndSons.com

**144" x 72" x 72"**  
**WWUD 6" Fire Water Meter**

Date: 2.142025

Drawn By: Samantha Lowe