

Top View

**Notes:**  
4" Inlet/Outlet (standard)

ASTM C 990 Butyl Sealant

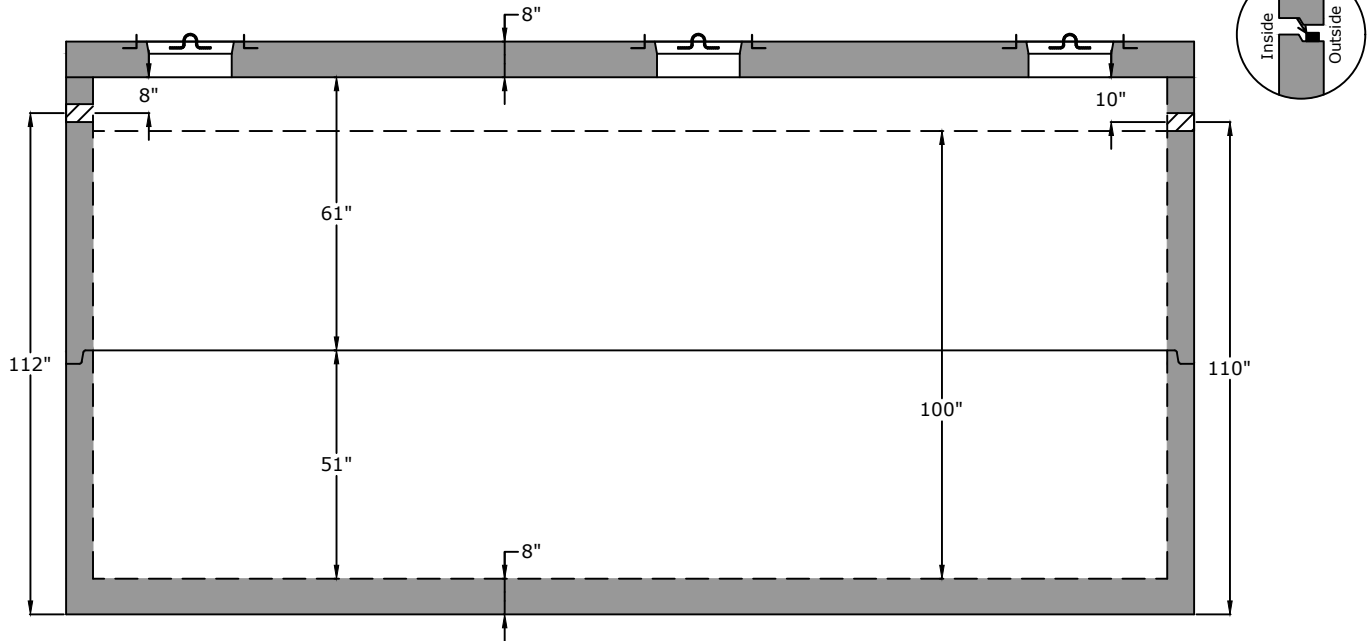

Side View

**Specifications**

**Concrete:** 5,000 psi minimum strength (28 day)  
**Reinforcing:** Primary reinforcement will be rebar.  
**Risers:** Grade rings and manhole frames and covers sold separately.  
**Sealant:** Sealant used in the seam of the tank will meet or exceed ASTM C990.  
**Pipe Penetrations:** Inlet and outlets are fitted with seals that meet or exceed all ASTM C923 specifications.  
**Partition Wall:** The partition wall, if present, is poured monolithically.  
**Drawing:** All measurements are accurate within  $\pm 1$  inch.

**Tank Warranty:** See Terms & Conditions.

**Centroid(s):** Lid (126, 54), Riser (126, 54) Base (126, 54)

**BARGER**  
PRECAST

**Weights**  
 Top - 18,095 lb  
 Riser - 21,818 lb  
 Bottom - 36,889 lb  
**Anti-Float Protection**  
 28" of water

**Installation:** The tank hole is not to be more than 18 in. longer and wider than the tank. There shall be a minimum of 6" of 3/4" stone bedding. Do not install across path of vehicles or heavy equipment. This tank is designed for one hundred fifty pounds per square foot (150 lb/ft<sup>2</sup>) uniform loading on the top of the tank with a max backfill cover of 36" and a minimum of 6".

**10,000 Gallon Septic Tank SC**

P.O. Box 370 - Kingston TN 37763  
 Phone 888.882.5860 - BargerPrecast.com

Date: 3.152018

Drawn By: Eric Barger

Updated: 7.232025