

Top View

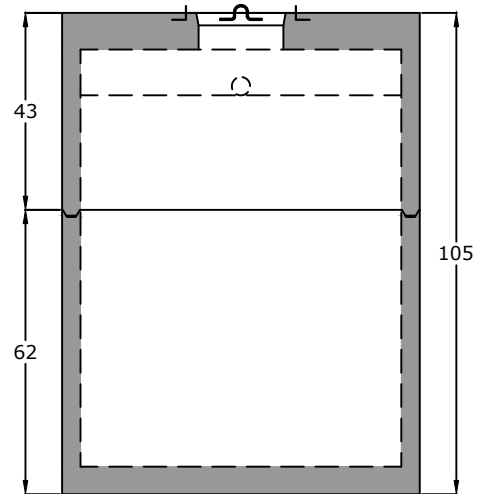

End View

Notes:

- HS20 Traffic Rated
- 4" Inlet/Outlet (Standard)
- 2/3 - 1/3 Compartment Capacity

ASTM C 990 Butyl Sealant

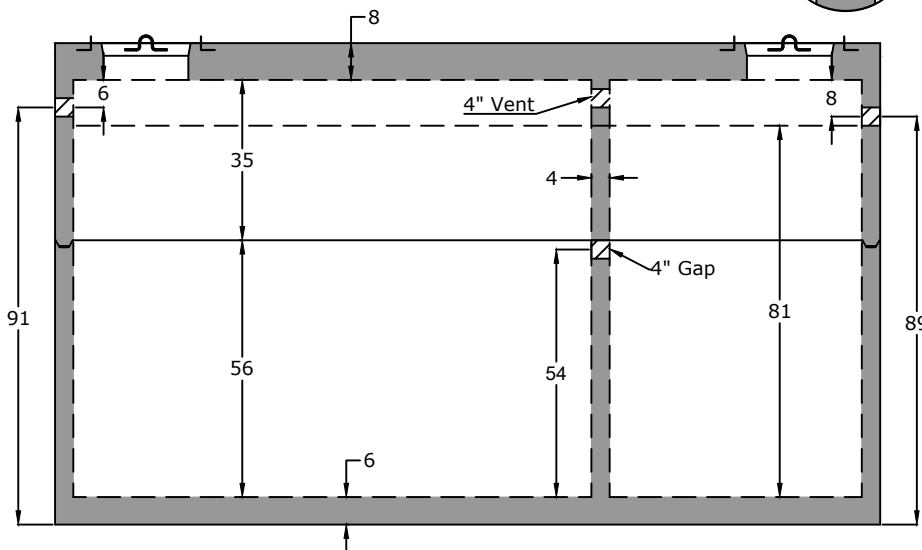
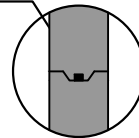

Side View

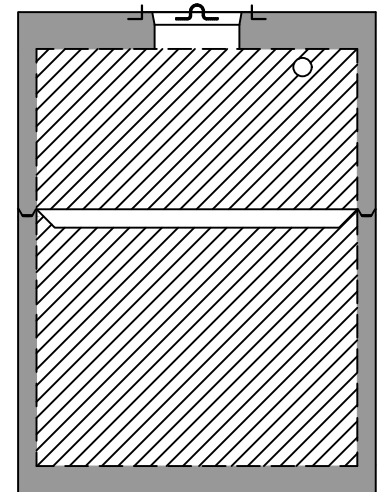

Baffle View

Specifications

- Concrete:** 5,000 psi minimum strength (28 day)
- Reinforcing:** Primary reinforcement will be rebar.
- Risers:** Grade rings and manhole frames and covers sold separately.
- Sealant:** Sealant used in the seam of the tank will meet or exceed ASTM C990.
- Pipe Penetrations:** Inlet and outlets are fitted with seals that meet or exceed all ASTM C923 specifications.
- Partition Wall:** The partition wall, if present, is poured monolithically.
- Drawing:** All measurements are accurate within ± 1 inch.

Tank Warranty: See Terms & Conditions.

Centroid(s): Lid (92, 39), Base (92, 39)

**BARGER
PRECAST**

P.O. Box 370 - Kingston TN 37763
Phone 888.882.5860 - BargerPrecast.com

Weights

Top - 16,086 lb
Bottom - 18,151 lb

Anti-Float Protection

45" of water

Installation: The tank hole is not to be more than 18 in. longer and wider than the tank. There shall be a minimum of 6" of 3/4" stone bedding. This tank is designed for HS20 traffic loads and with a max backfill cover of 3' and a minimum of 6". Water table at 6'.

4,000 Gallon HS20 Septic Tank

Date: 5.102010

Drawn By: Eric Barger

Updated: 7.222024