

Top View

- Notes:**  
 HS20 Traffic Rated  
 4" Inlet/Outlet (Standard)  
 2/3 - 1/3 Compartment Capacity

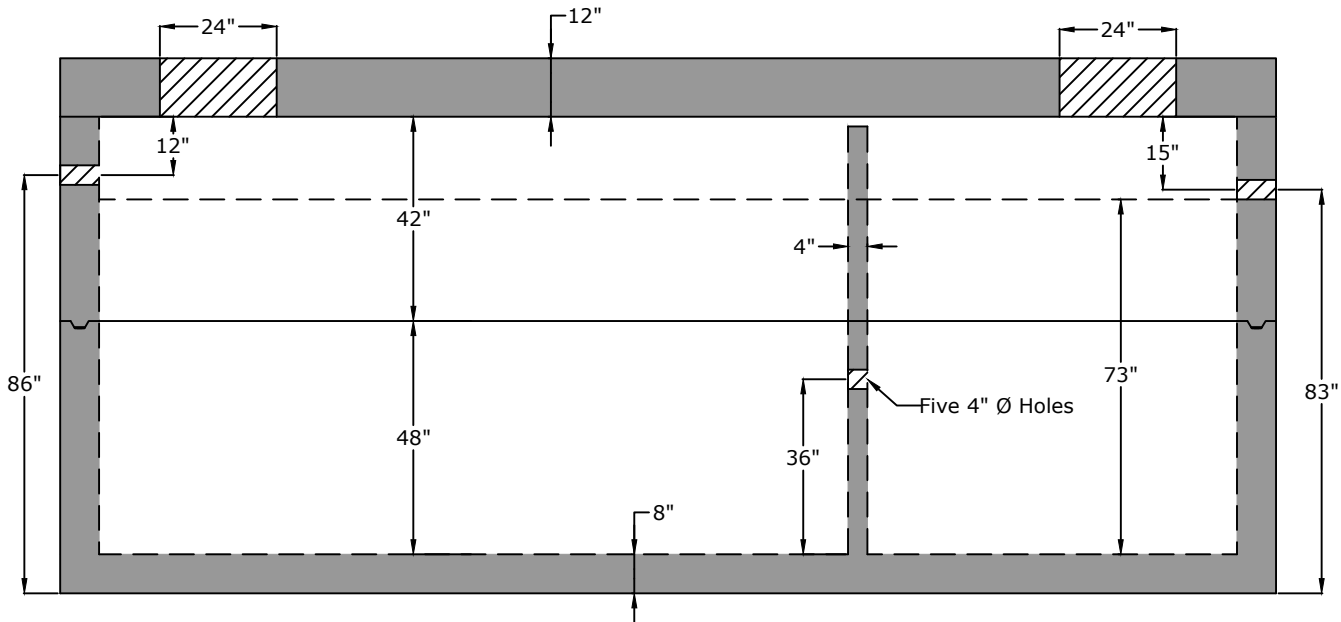

Side View

**Specifications**

**Concrete:** 5,000 psi minimum strength (28 day)  
**Reinforcing:** Primary reinforcement will be rebar.  
**Risers:** Grade rings and manhole frames and covers sold separately.  
**Sealant:** Sealant used in the seam of the tank will meet or exceed ASTM C990.  
**Pipe Penetrations:** Inlet and outlets are fitted with seals that meet or exceed all ASTM C923 specifications.  
**Partition Wall:** The partition wall, if present, is poured monolithically.  
**Drawing:** All measurements are accurate within  $\pm 1$  inch.

**Tank Warranty:** See Terms and Conditions.

**Centroid(s):** Lid (125, 49), Riser (127, 49) Base (126, 49)

**BARGER  
 PRECAST**

**Weights**  
 Top - 24,251 lb  
 Riser - 19,108 lb  
 Bottom - 38,625 lb  
**Anti-Float Protection**  
 0" of water

**Installation:** The tank hole is not to be more than 18 in. longer and wider than the tank. There shall be a minimum of 6" of 3/4" stone bedding. This tank is designed for HS20 traffic loads with a max backfill cover of 6' and a minimum of 6".

P.O. Box 370 - Kingston TN 37763  
 Phone 888.882.5860 - BargerPrecast.com

**6000 HS20 Septic Tank**

Date: 10.072021 Drawn By: Eric Barger Updated: 6.212024