

Top View

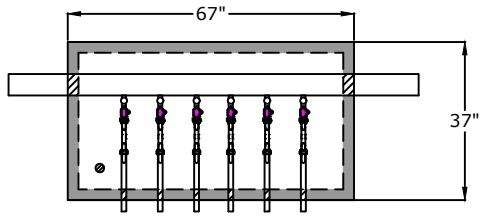

Side View

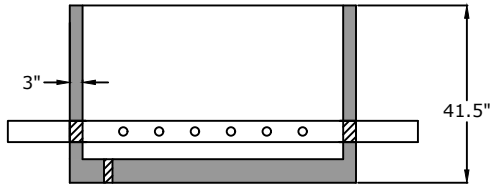

End View

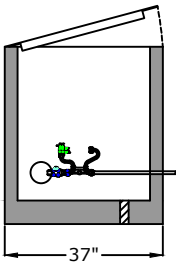

Component Detail

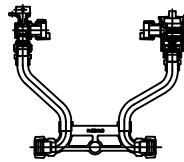

Pipe Detail for Taps

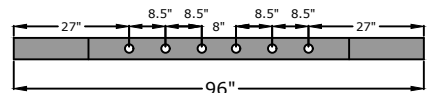

1. Tapping Saddle:
Smith Blair 313 or Ford F202 with CC Threads
2. Corp Stop:
Ford: F-1600-4-NL Style
3. Brass Nipple (IP Threads) if required
4. Meter Yoke:
Ford: 1" - VB74-10W-14-44-Q-NL

Cut Sheets to be provided to Engineer on all setters
5. 4" Class 52 or 53 DIP
6. 2" Drain Hole
7. Hatch:
Material: Aluminum with 316 SS nuts and tamper-proof bolts, hinges, hold open arm, SS horizontal springs, SS slamlock and flush drop handle

Loading: 300 lbs / sq. ft.
8. Tag / Label (by others):
Emedco VC2022 6" tag or equivalent accepted by engineer.

Note: Unit number must be clearly displayed on tag and or label. Meters will not be set by the City until each line has been properly identified.

Approved for Production

Project: _____ Date: _____

Quantity: _____ By: _____



Specifications

Concrete: 5,000 psi minimum strength (28 day)
Pipe Penetrations: All pipe penetrations are placed according to job requirements.

**6-Gang 1" Meter Vault
City of Cookeville**

P.O. Box 370 - Kingston TN 37763
Phone 888.882.5860 - BargerPrecast.com

Date: 2.202026 Drawn By: Samantha Mills Approx. Empty Weight: 3,100 lbs.

SUBMITTAL INFORMATION

Iron Service Saddles - (F202-xxx-TAP style)

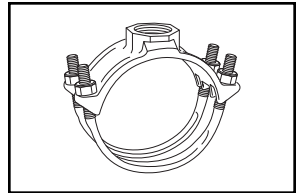

F202 DOUBLE STRAP IRON SERVICE SADDLES

Finish: Black E-Coating

Closed lug

EPDM Gasket

Zinc plated carbon steel strap

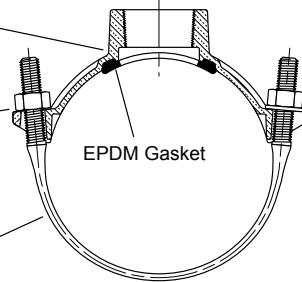

Zinc plated steel nuts

Zinc plated washers (open lug side)

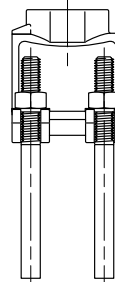

NOM. PIPE SIZE	O.D. RANGE	APPROX. WT. LBS.	CATALOG NUMBER	✓ SUBMITTED ITEM(S)
2"	*2.35 - 2.50	2.8	F202-250-TAP	
2-1/2"	*2.75 - 2.90	2.8	F202-290-TAP	
3"	**3.80	4.8	F202-380-TAP	
	**3.80 - 4.25	5.5	F202-425-TAP	
4"	***4.26 - 4.80	5.4	F202-480-TAP	
	▲ 4.74 - 5.00	5.4	F202-500-TAP	
	**4.74 - 5.26	5.4	F202-526-TAP	
	▲ 4.97 - 5.26	5.4	F202-526-TAP	
	5.94 - 6.69	6.5	F202-669-TAP	
6"	6.63 - 6.90	6.5	F202-690-TAP	
	6.84 - 7.60	6.8	F202-760-TAP	
	7.93 - 8.71	7.4	F202-871-TAP	
8"	8.63 - 9.05	7.4	F202-905-TAP	
	8.99 - 9.79	8.2	F202-979-TAP	
	10.00 - 10.75	10.4	F202-1075-TAP	
10"	10.75 - 11.10	11.5	F202-1110-TAP	
	11.10 - 12.12	11.5	F202-1212-TAP	
	12.00 - 12.75	12.5	F202-1275-TAP	
12"	12.75 - 13.20	12.5	F202-1320-TAP	
	13.20 - 14.38	12.5	F202-1438-TAP	
	15.30 - 16.25	16.0	F202-1625-TAP	
14"	16.30 - 17.25	16.5	F202-1725-TAP	
	17.40 - 18.40	17.0	F202-1840-TAP	
16"	18.50 - 19.25	17.3	F202-1925-TAP	
18"	19.50 - 20.50	20.8	F202-2050-TAP	
20"	21.20 - 22.20	21.3	F202-2220-TAP	
	22.50 - 23.50	24.0	F202-2350-TAP	
24"	23.80 - 24.80	24.5	F202-2480-TAP	
	25.60 - 26.50	31.7	F202-2650-TAP	
30"	31.74 - 32.74	42.0	F202-3274-TAP	

OUTLET TAP CODE

CC (AWWA) THREAD

THREAD	CODE NUMBER	✓ SUBMITTED ITEM(S)
3/4" CC	CC3	
1" CC	CC4	
1-1/4" CC	Δ CC5	
1-1/2" CC	CC6	
2" CC	CC7	

IP THREAD

THREAD	CODE NUMBER	✓ SUBMITTED ITEM(S)
3/4" IP	IP3	
1" IP	IP4	
1-1/4" IP	Δ IP5	
1-1/2" IP	IP6	
2" IP	IP7	
2-1/2" IP	IP8	

Δ Contact factory for availability

* Saddles for this pipe range are only available with 3/4" and 1" taps

** Saddles for this pipe range are not available with 2" CC (CC7) or 2-1/2" IP (IP8) taps.

*** These saddles with 2" CC (CC7) or 2-1/2" IP (IP8) taps only fit 4.80" O.D. pipe.

Example: F202-480-CC7 fits 4.80 pipe O.D. only.

▲ This saddle is only available with 2" CC (CC7) or 2-1/2" IP (IP8) taps.

FEATURES

- Body made of high strength ductile iron per ASTM A536
- Straps are 5/8" AISI C1010 steel, zinc plated with Di-chromate or Trivalent seal. Each strap has 5/8" flat bearing surface. 1/2" straps are furnished on saddles 3" and smaller
- Gasket is EPDM rubber, ASTM D2000
- Finish on saddle body is black e-coating
- UL Classified to ANSI/NSF Standard 61

The Ford Meter Box Company considers the information in this submittal form to be correct at the time of publication. Item and option availability, including specifications, are subject to change without notice. Please verify that your product information is current.



The Ford Meter Box Company, Inc.

P.O. Box 443, Wabash, Indiana U.S.A. 46992-0443

Phone: 260-563-3171 / Fax: 800-826-3487

Overseas Fax: 260-563-0167

www.fordmeterbox.com

10/15/15

Submitted By:

SUBMITTAL INFORMATION

Corporation Stops - (F1600-x-NL style)

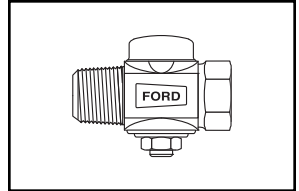

AWWA/CC TAPER THREAD INLET BY FEMALE IRON PIPE THREAD OUTLET

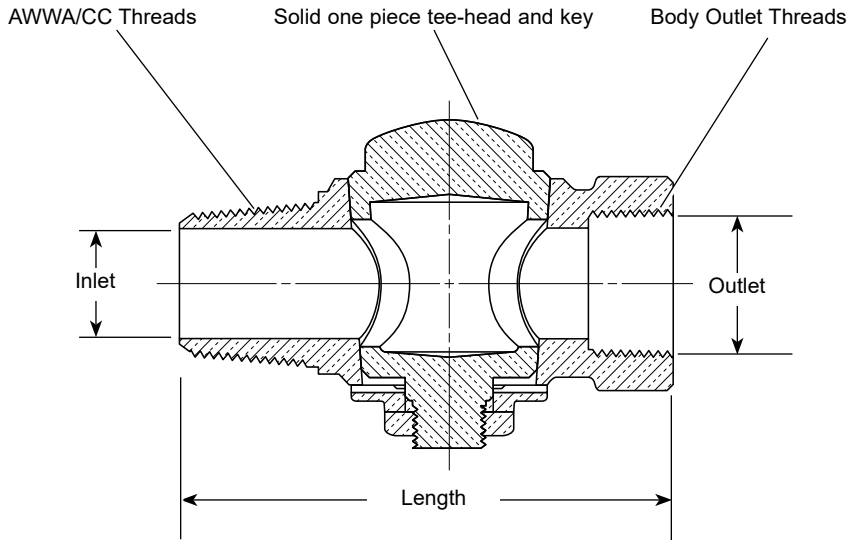

VALVE SIZE	INLET SIZE	OUTLET SIZE	VALVE LENGTH	BODY OUTLET THREADS	APPROX. WT. LBS	PART NUMBER	✓ SUBMITTED ITEM(S)
3/4"	3/4"	3/4"	3-3/4"	3/4" FIP	1.4	F1600-3-NL	
1"	1"	1"	4-3/8"	1" FIP	2.2	F1600-4-NL	

FEATURES

- All brass that comes in contact with potable water conforms to AWWA Standard C800 (ASTM B584, UNS C89833)
- The product has the letters "NL" cast into the main body for lead-free identification
- Certified to NSF/ANSI Standard 61 and NSF/ANSI Standard 372 where applicable
- Brass components that do not come in contact with potable water conform to AWWA Standard C800 (ASTM B62 and ASTM B584, UNS C83600, 85-5-5-5)
- Body design provides larger, more rugged wrench flats for proper installation
- Meets 100 PSI working pressure requirement of AWWA Standard C800

The Ford Meter Box Company considers the information in this submittal form to be correct at the time of publication. Item and option availability, including specifications, are subject to change without notice. Please verify that your product information is current.



The Ford Meter Box Company, Inc.

P.O. Box 443, Wabash, Indiana U.S.A. 46992-0443

Phone: 260-563-3171 / Fax: 800-826-3487

Overseas Fax: 260-563-0167

www.fordmeterbox.com

10/03/16

Submitted By:

SUBMITTAL INFORMATION

70 Series Coppersetter - (VB74-xxW-14-44-Q-NL style)

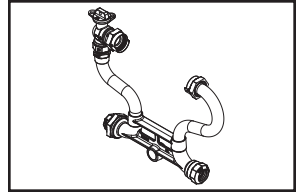

ANGLE BALL VALVE BY METER NUT (1" METER)

DOUBLE PURPOSE UNION SWIVEL INLET BY QUICK JOINT FOR COPPER OR PLASTIC TUBING (CTS) OUTLET

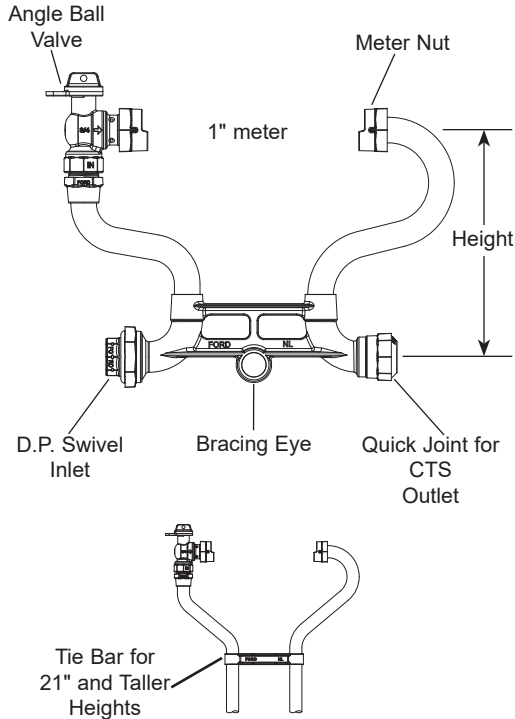

Coppersetter Part Number

HEIGHT (INCHES)	APPROX. WT. LBS.	CATALOG NUMBER	✓ SUBMITTED ITEM(S)
10	7.5	VB74-10W-14-44-Q-NL	
12	7.6	VB74-12W-14-44-Q-NL	
15	7.9	VB74-15W-14-44-Q-NL	
18	8.2	VB74-18W-14-44-Q-NL	
21	9.7	VB74-21W-14-44-Q-NL	
24	10.1	VB74-24W-14-44-Q-NL	
27	10.4	VB74-27W-14-44-Q-NL	
30	10.7	VB74-30W-14-44-Q-NL	
33	11.0	VB74-33W-14-44-Q-NL	
36	11.3	VB74-36W-14-44-Q-NL	
39	11.6	VB74-39W-14-44-Q-NL	
42	11.9	VB74-42W-14-44-Q-NL	

Service Line Size

INLET	OUTLET
1" D.P. Swivel	1" (CTS) Q.J.

FEATURES

- All brass that comes in contact with potable water conforms to AWWA Standard C800 (ASTM B584, UNS C89833)
- The product has the letters "NL" cast into the main body for lead-free identification
- Brass components that do not come in contact with potable water conform to AWWA Standard C800 (ASTM B62 and ASTM B584, UNS C83600, 85-5-5-5)
- Certified to NSF/ANSI/CAN Standard 61 and NSF/ANSI/CAN Standard 372 where applicable
- Copper conforms to ASTM B75 or B88, UNS C12200
- All Ford® Setters are assembled with lead-free solder
- Saddle nuts hold the meter in place for tightening
- Bracing eye is standard on all 70 Series Coppersetters
- Tie bar is standard for 21" and taller Coppersetter heights (74 Series)
- Double purpose union swivels will accommodate male iron pipe threads or flare copper
- 1-1/8" copper risers provide more flow capacity

The Ford Meter Box Company considers the information in this submittal form to be correct at the time of publication. Item and option availability, including specifications, are subject to change without notice. Please verify that your product information is current. Our standard warranty applies.

FORD **The Ford Meter Box Company, Inc.**
 P.O. Box 443, Wabash, Indiana U.S.A. 46992-0443
 Phone: 260-563-3171 / Fax: 800-826-3487
 Overseas Fax: 260-563-0167
www.fordmeterbox.com

03/13/25

Submitted By: _____