

Top View

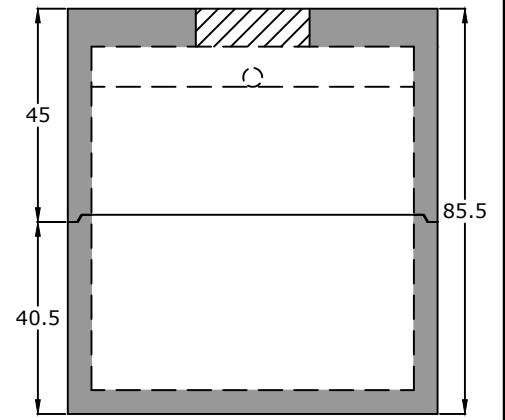

End View

Notes:
 HS20 Traffic Rated
 4" Inlet (Standard)

ASTM C 990 Butyl Sealant

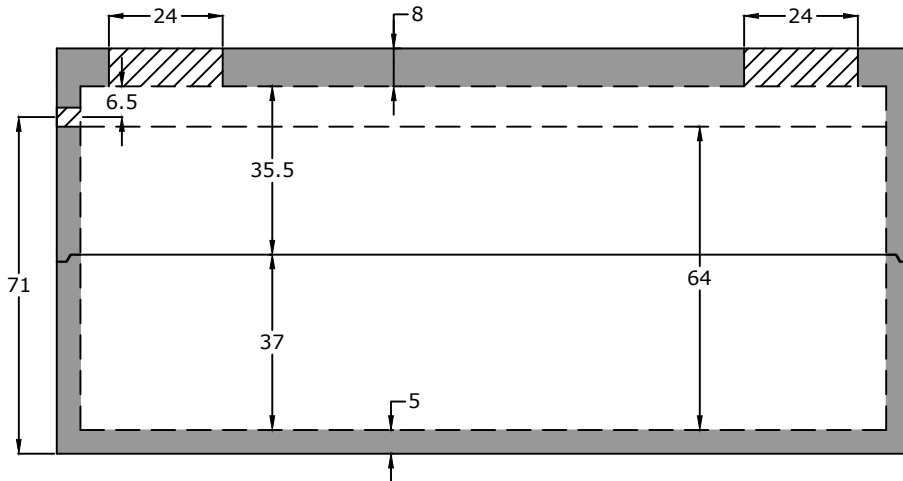
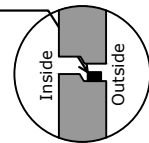

Side View

Specifications

Concrete: 5,000 psi minimum strength (28 day)
Reinforcing: Primary reinforcement will be rebar.
Risers: Grade rings and manhole frames and covers sold separately.
Sealant: Sealant used in the seam of the tank will meet or exceed ASTM C990.
Pipe Penetrations: Inlet and outlets are fitted with seals that meet or exceed all ASTM C923 specifications.
Partition Wall: The partition wall, if present, is poured monolithically.
Drawing: All measurements are accurate within ± 1 inch.

Tank Warranty: See Terms & Conditions.

Centroid(s): Lid (90, 39), Base (90, 39)

**BARGER
 PRECAST**

Weights

Top - 16,792 lb
 Bottom - 13,872 lb

Anti-Float Protection

31" of water

Installation: The tank hole is not to be more than 18 in. longer and wider than the tank. There shall be a minimum of 6" of 3/4" stone bedding. This tank is designed for HS20 traffic loads and with a backfill cover between 2' - 5'. Water table assumed at top of tank.

P.O. Box 370 - Kingston TN 37763
 Phone 888.882.5860 - BargerPrecast.com

3,000 Gallon HS20 Pump Tank

Date: 1.122022

Drawn By: Samantha Lowe

Updated: 3.212025